

Trapèze

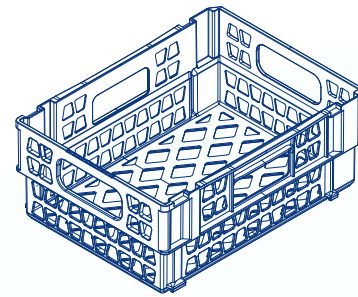

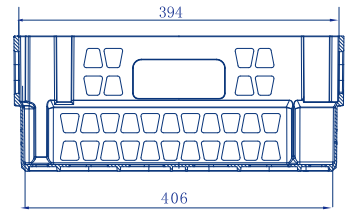

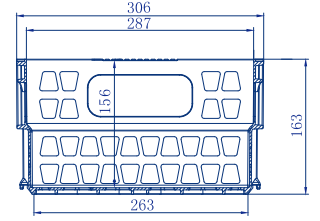

Informations générales - General information - معلومات عامة

		610 ± 5 gr
الوزن Weight Poids		
	Dimension exterieures - External sizes - المقاييس الخارجية	406 x 306x163 mm
المقياس Dimension Volume	Dimension intérieures - Interior sizes - المقاييس الداخلية	394 x 287x 156 mm
		بوليبروبيلان غذائي مع حماية من اشعة الشمس Alimentary Polypropylène +UV protection Polypropylène alimentaire + UV protection des ryons uv
المادة Material Matière		
	ملون حسب رغبة الخريف ينصح استعمال الالوان الباردة Color following customer specification recommended to use cold colors Coloré suivant spécification client recommandé d'éviter les couleurs chaudes	
اللون Colour Couleur		
	Manutention - Handling - التصريف	يرصف و يكوم بالعكس Stackable empilables boxes by reversal Gerbables-empilables par retournement
النوع Type Type		
	Aération - Aeration - التهوية	يضمن التهوية. للتصريف في البراد Guarantee the cold air circulation around all sides of the load Bonne aération pour stockage en chambre froide
التبريد Aeration Aération		
	Manutention - Handling - الاستعمالات	يتحمل الصدمات و التعنف Resist to chock Résistance au choqe et à la vulgarité
الصدمات Hurts Choque		



Informations logestique - Logistics information - التعبئة و الشحن

	Charge Nette - Net charge - الحمولة الصافية	8,5 ± 0,5 kg
الحمولة Charge Charge		
	Conditionnement - Package - التصريف	10 x 25 pcs
التعبئة Package Emballage	Hauteur palette - Height pallet - مقاييس التصريف	1 x 1.2 m - 2.33 m
	Charge statique - Static loading capacity - الحمولة القصوى	1+8 (80 Kg)
الحمولة Charge Charge		
	Contenaire 20 Pied - 20 foot container - حاوية 20 قدم	2250 pcs
الشحن Export Transport	Contenaire 40 Pied - 40 foot container - حاوية 40 قدم	5000 pcs
	Contenaire 40 Pied H.C - Height cube 40 foot container - حاوية 40 قدم عالي الارتفاع	5400 pcs

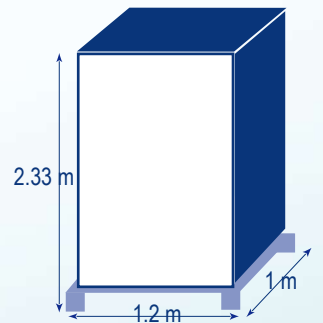

Rq : Les clients sont priés de vérifier et tester nos produits dans des conditions d'utilisation réelles pour s'assurer s'ils répondent à leurs exigences